

Subtract by taking the ones' complement of the B-operand and SET the Carry-In (SW1) to obtain the two's complement.

Cut JP1 and use J5 and J8 to chain more 8-bit Adders (e.g. to create a 16-bit Full Adder).

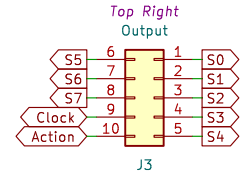
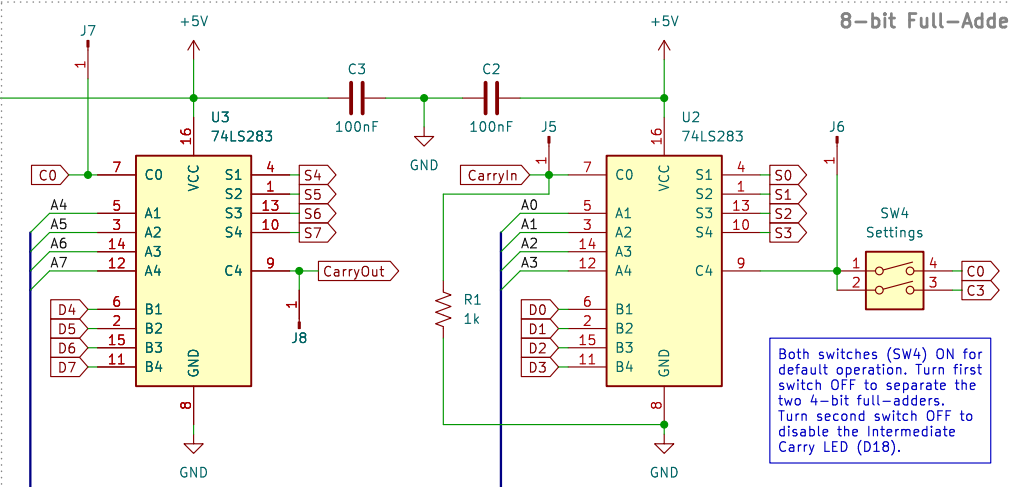
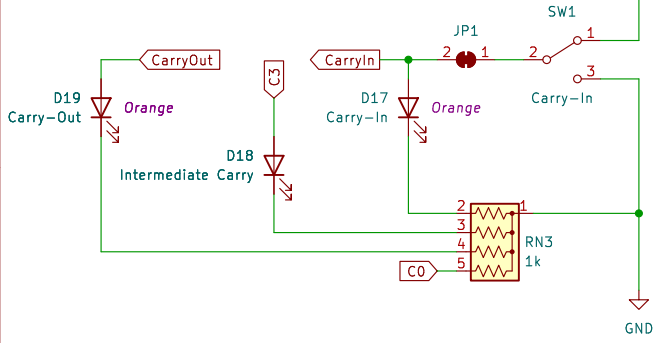

The sum of operand A (D1-D8) and operand B (D9-D16) is set on the Output (J3, S0-S7).

Use the Action-button on the 8-bit Workbench to execute an Add. Make sure to set the A -> C jumper and use normal signal settings. Jumpers J9 and J10 can be left out.

Both switches (SW4) ON for default operation. Turn first switch OFF to separate the two 4-bit full-adders. Turn second switch OFF to disable the Intermediate Carry LED (D18).

Accumulator (operand A)

Press SW3 to Load the data at the input (J4) in the Accumulator.

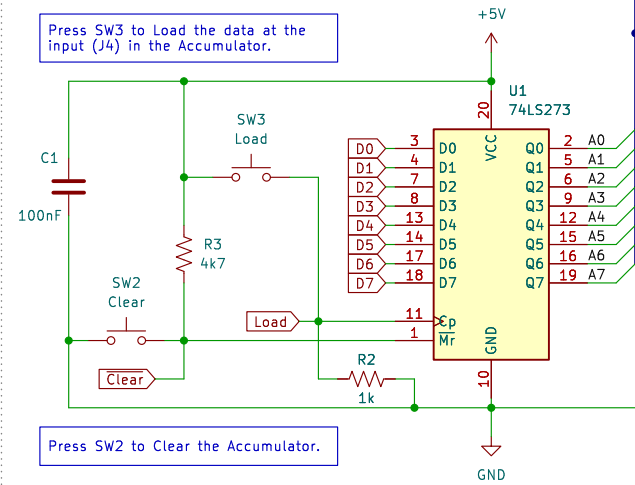

Press SW2 to Clear the Accumulator.

Tip: do a Clear, followed by Action to see the input-data (J4) on the 8-bit Workbench. Make sure to leave the Carry-in (SW1) UNSET.

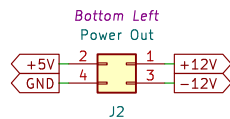

Attach a Binary Keyboard or Hex Keyboard. The data input (J4) is used as operand B (shown by D9-D16). Use their 'Flip the Bits'-switch to obtain a ones' complement, used for subtraction.

A parallel ASCII keyboard can be used as well, using the digits 0-9 for numerical input. The high nibble (D4-D7) should be discarded in order to obtain the correct values.

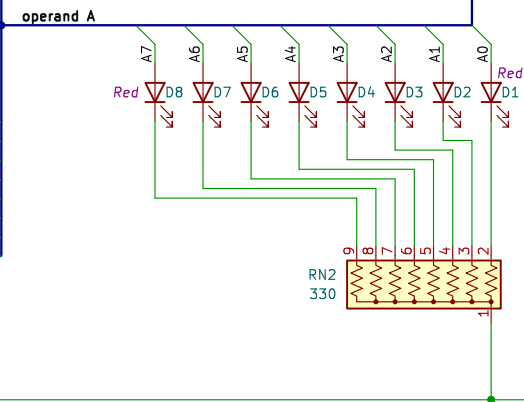

Input (operand B)

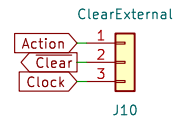
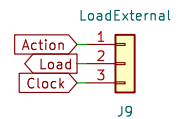
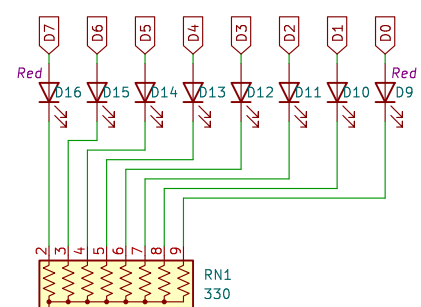

Optionally, the Action and Clock signals can be wired to Load and Clear using the jumpers J9 and J10.

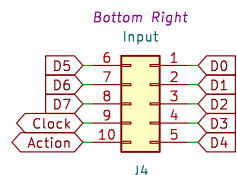

An 8-bit Full Adder, with Accumulator to store one operand. Do binary addition (and subtraction) together with the 8-bit Workbench and a Binary (or Hex) Keyboard.

Gain understanding of the inner workings of an Arithmetic Logic Unit (ALU), one of the building blocks of processors. Subtract using the method of complements.

8BitFlux.com / Bobby Nijssen

Sheet: /
File: AdderSubtractor.kicad_sch

Title: Byte Adder Subtractor

Size: A4 Date: 2026-03-25
KiCad E.D.A. 9.0.5

Rev: 1
Id: 1/1